

IRC R302.6

2012 IRC

Garages beneath habitable rooms must be separated at the ceiling with 5/8" type X gypsum board. The structure supporting the separation and walls between the residence and garage must be protected by not less than 1/2" gypsum board.

Envelope

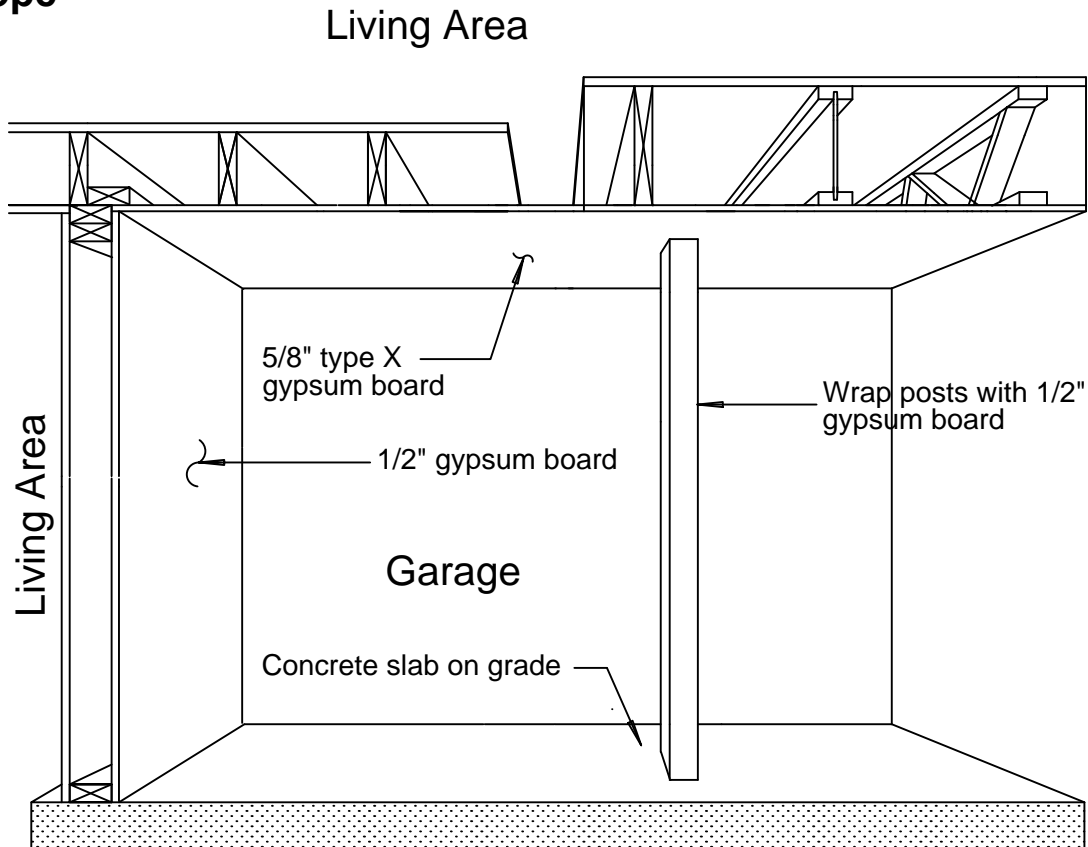

Dwelling / Garage Separation

NOTE:

Fastening per IRC Table R702.3.5:

5/8" type X at ceiling:

- Fasten with 6d cooler nails @ 7" o.c. or drywall screws @ 12" o.c. when framing is either 16" o.c. or 24" o.c.

1/2" gypsum board at walls:

- Fasten with 5d cooler nails @ 8" o.c. or drywall screws @ 16" o.c. when framing is 16" o.c.
- Fasten with 5d cooler nails @ 8" o.c. or drywall screws @ 12" o.c. when framing is 24" o.c.

GENERAL INFORMATION:

- Obtain a building permit before starting construction.
- The intent of this tip sheet is to address the basics of private residential garage construction only and does not address the subject in great detail. Additional information can be found at your local building department, home improvement store, or library.

Penetrations (of the protected envelope)

Ducts

R302.5.2
Ducts in the garage and ducts penetrating the walls or ceilings separating the dwelling from the garage must be a minimum of No. 26 gage sheet metal with no register outlets (openings) into the garage.

No requirements for pipe penetrations.

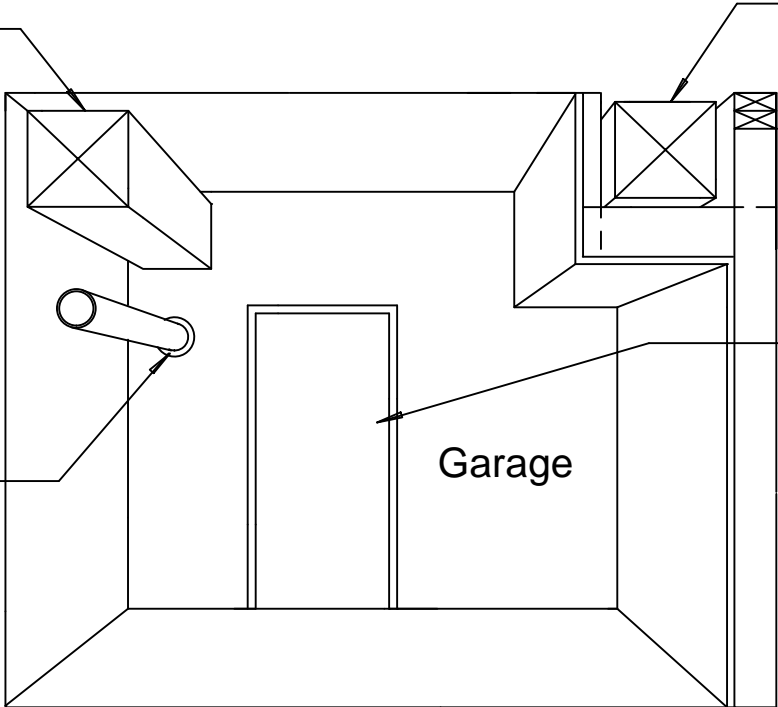

Ducts outside the protected envelope are excluded from these regulations.

Doors

Doors separating the garage and living room spaces are 1-3/8" solid wood, solid or honeycomb core steel doors not less than 1-3/8", or 20-minute fire-rated door.

Special Conditions

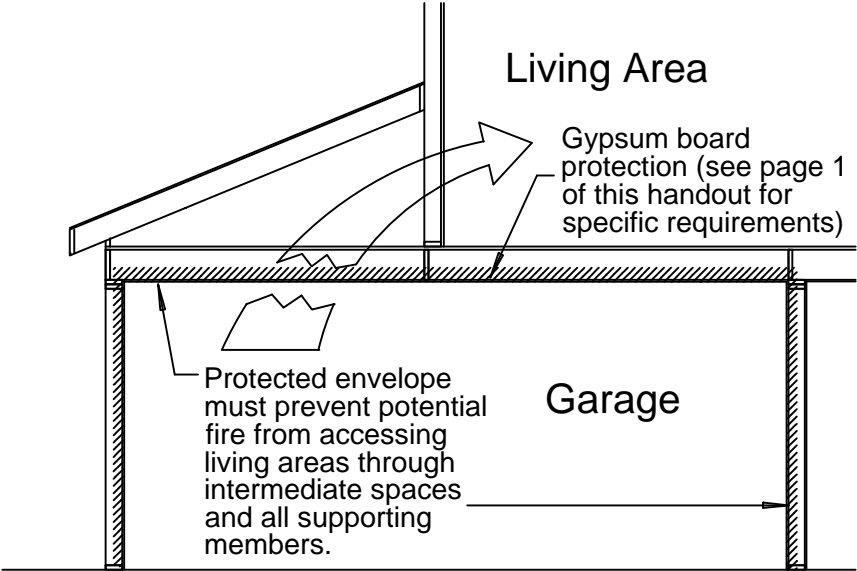

OR

