

2012 Codes

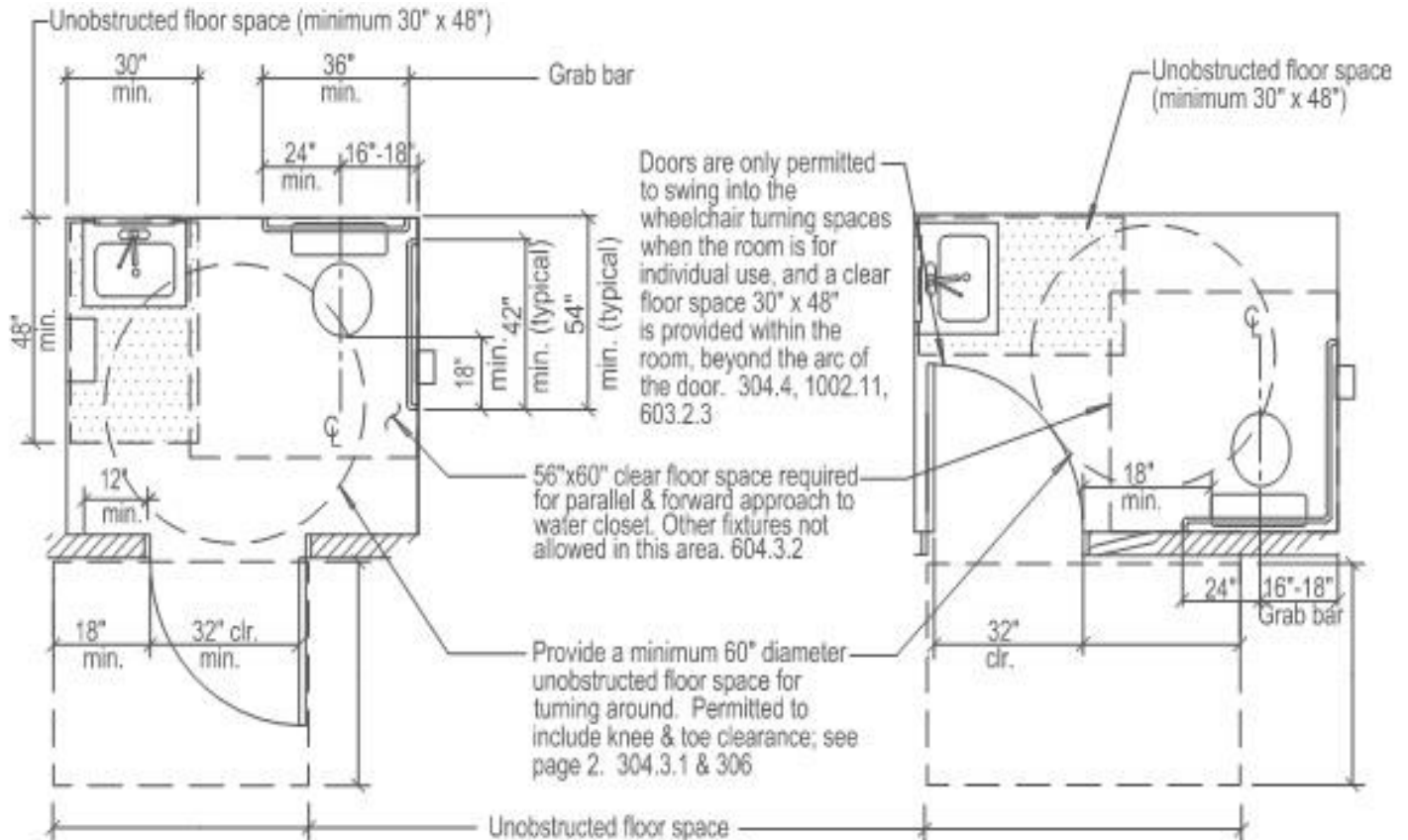

Outward Swinging Door Plan

Inward Swinging Door Plan

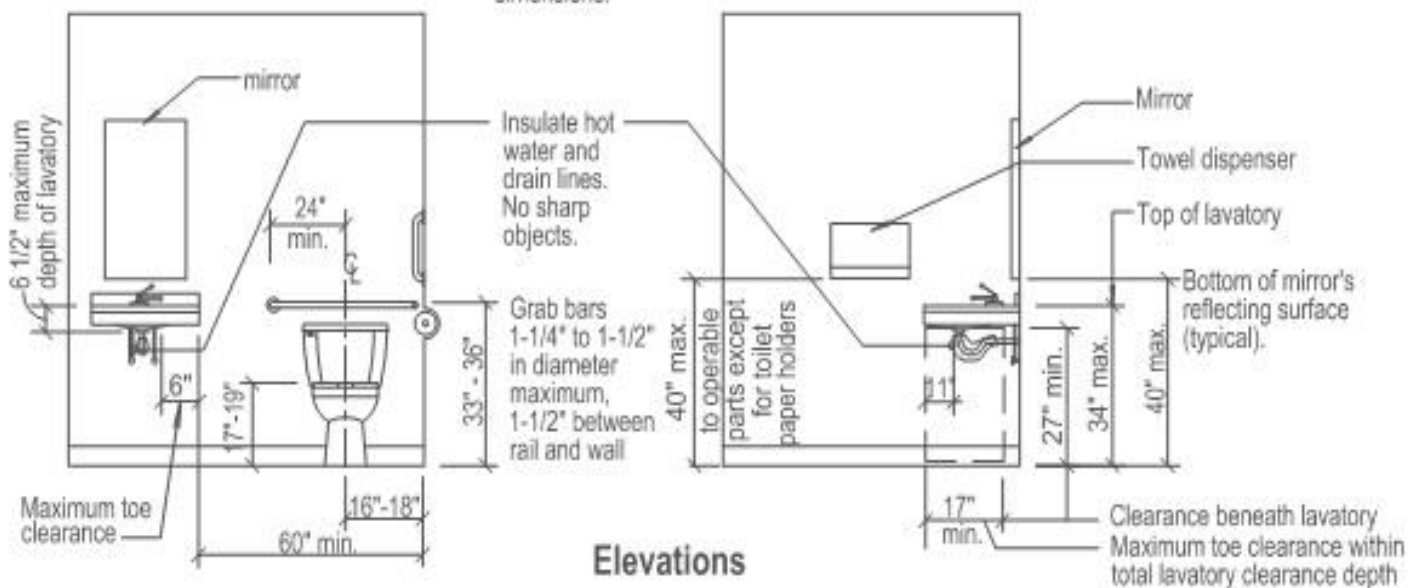

Elevations

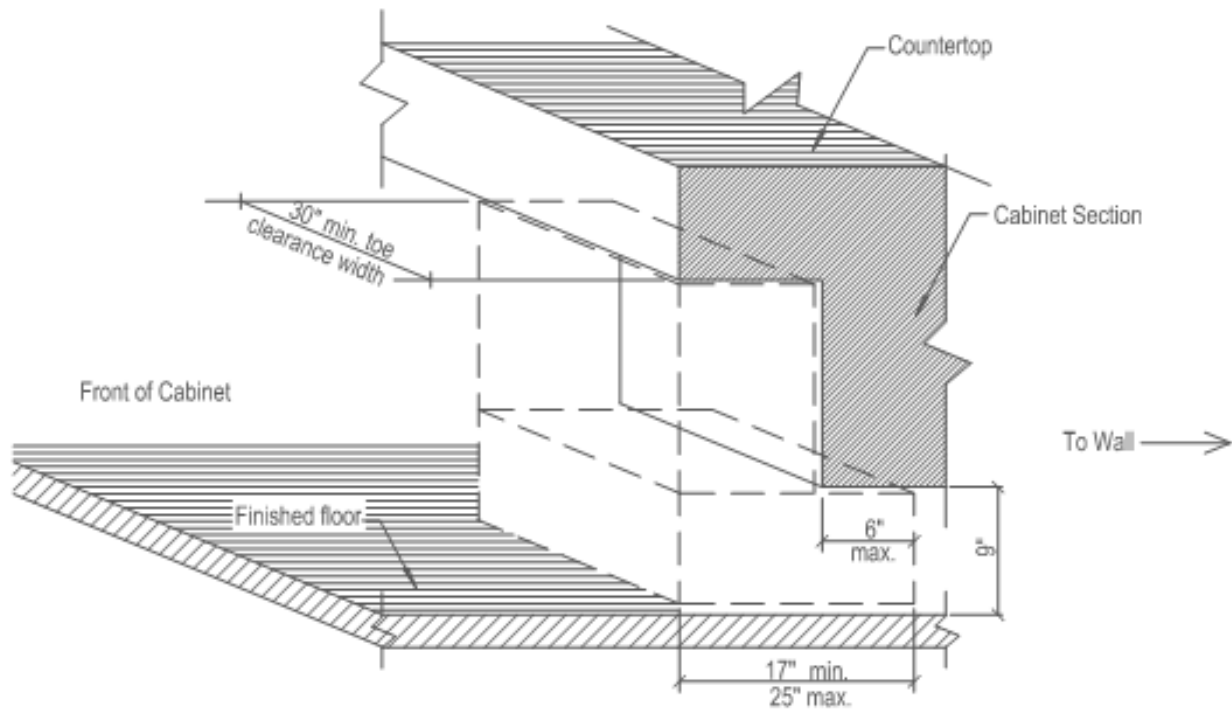

Toe Clearance

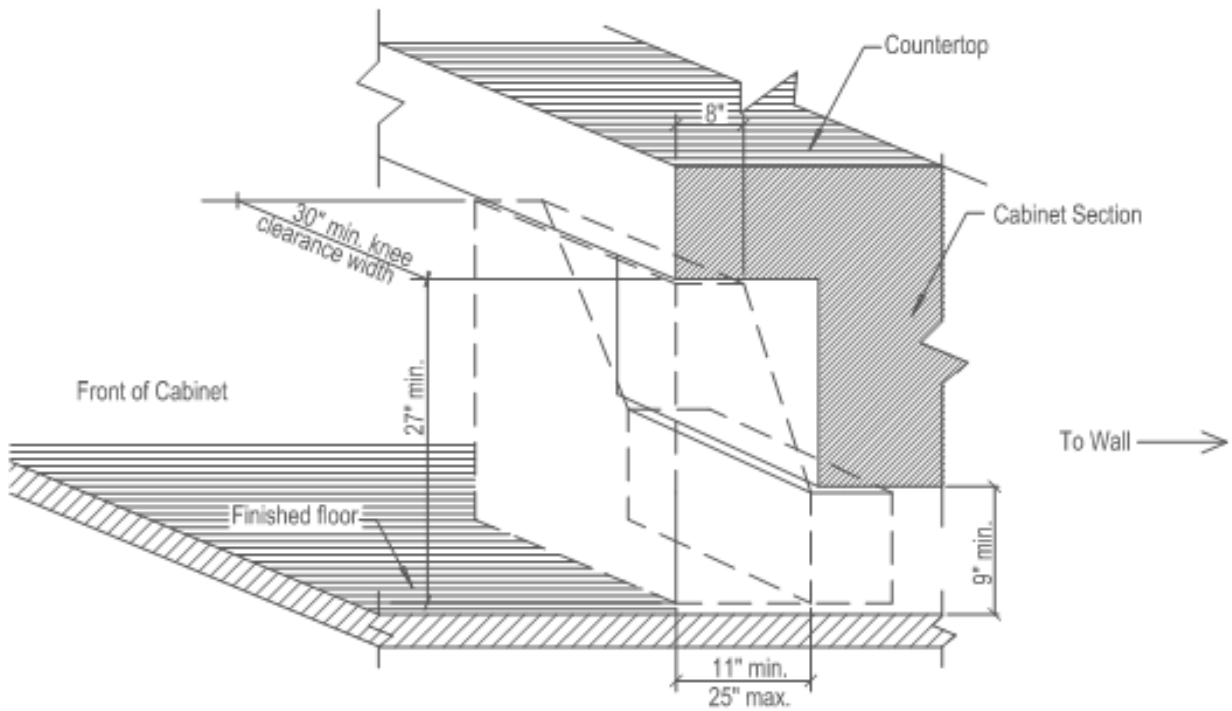

Knee Clearance

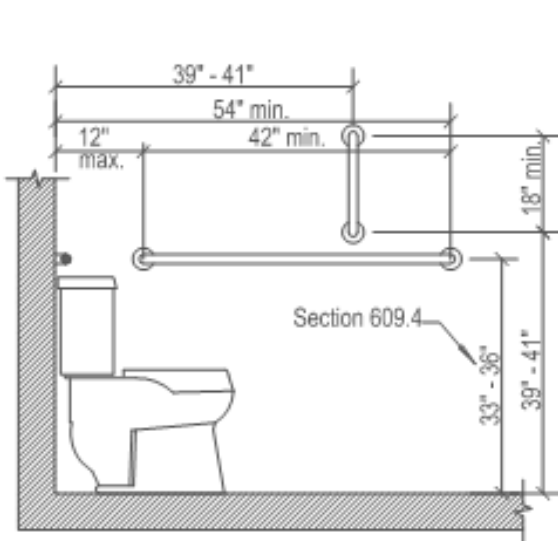

**Side Wall Grab Bar
for Water Closet**

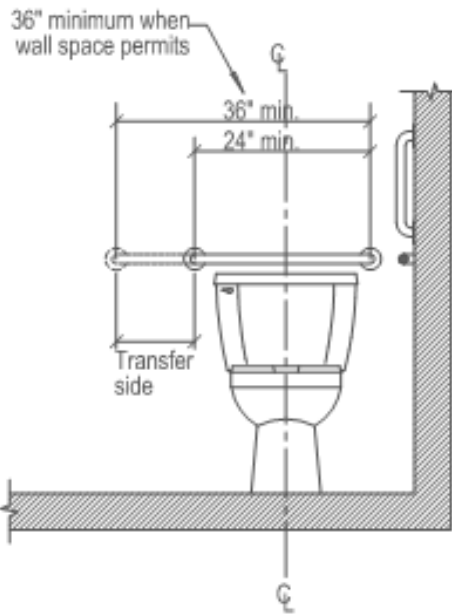

**Rear Wall Grab Bar
for Water Closet**

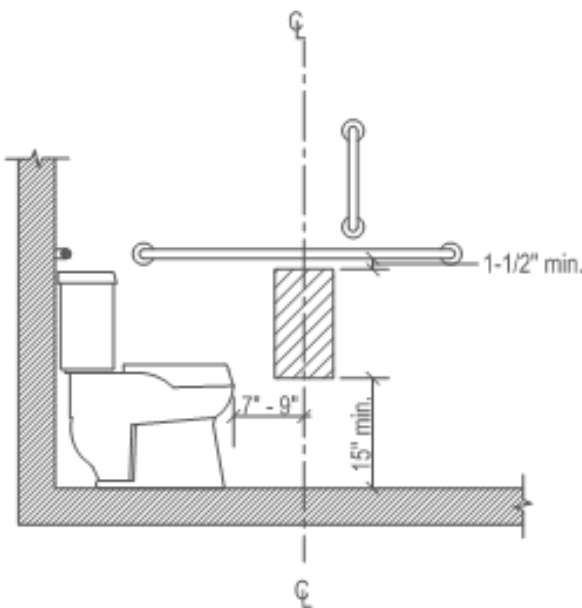

**Dispenser Location
Below Grab Bar**

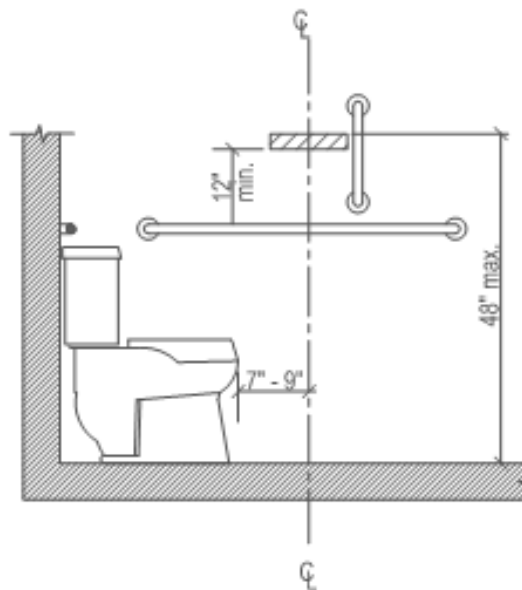

**Dispenser Location
Above Grab Bar**