

This Tip Sheet reflects code requirements of the 2015 International Residential Code (IRC) with Washington State Amendments which update the live load to 60 psf.

This document provides building code information applicable to **prescriptive residential wood deck design**. You may need to hire a licensed architect or an engineer to design a deck where any of the following conditions apply:

- The deck serves other than a one- or two-family dwelling building
- The deck design includes more than one level
- The deck will support a hot tub, spa or other heavy object, including heavy deck covering (such as pavers)
- The walking surface is more than 10' above grade
- The deck ledger is attached to house overhangs, bay windows, bricks, stone or concrete block
- The deck is bearing on ground with a slope greater than 1' horizontal for every 1' vertical
- The deck is self-supporting (not attached to an exterior wall)

Typical Deck

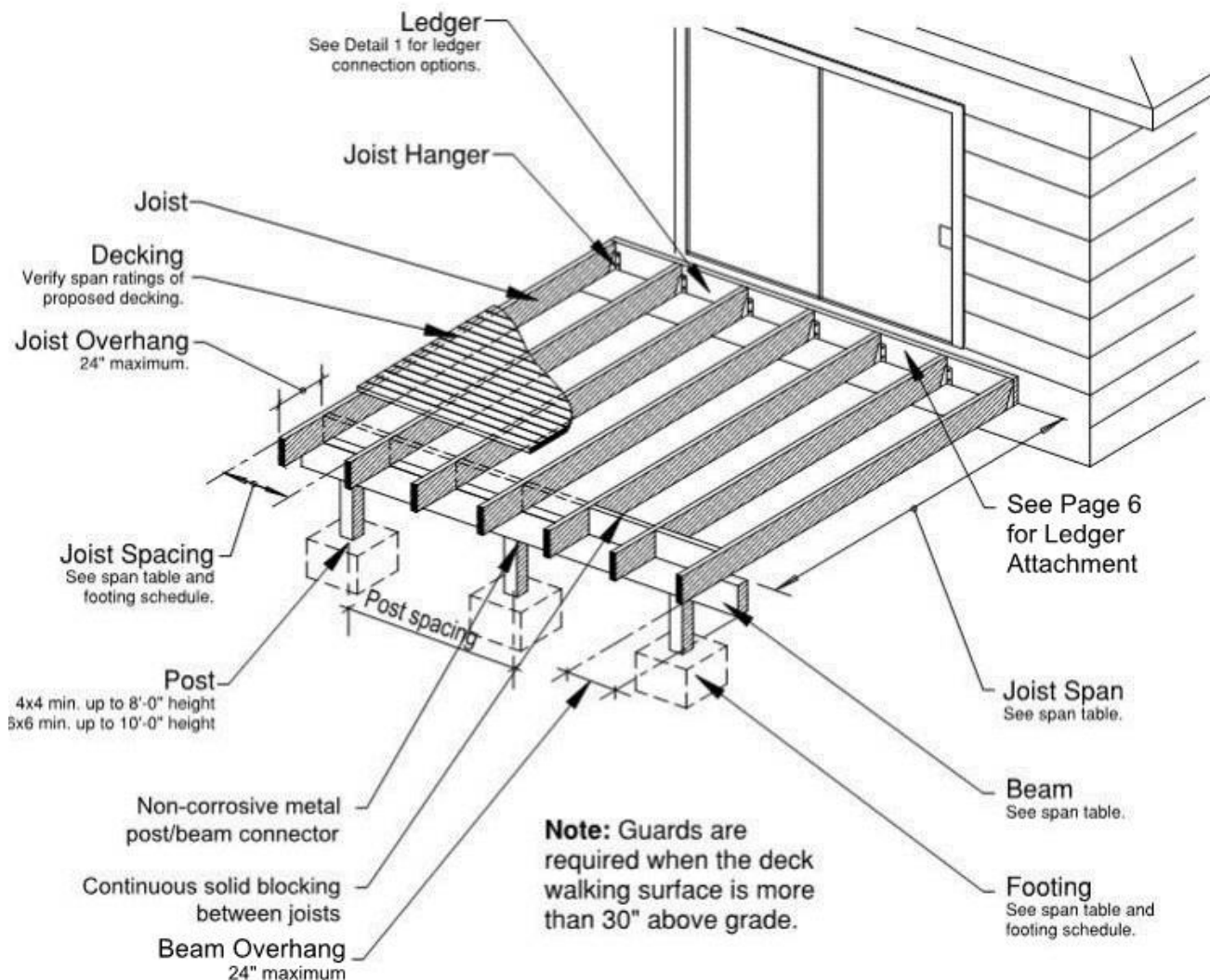

GENERAL INFORMATION:

- The intent of this Tip Sheet is to provide a general understanding of the code requirements and does not address the subject in great detail.
- Additional information can be obtained from your local participating jurisdiction.

Deck Construction Notes

- Please note that due to the new 60 psf loading, previous lumber spans and footing sizes have changed.
- The illustrations and information in this Tip Sheet may be used for decks whether or not they require a permit. See Tip Sheet 0 for when a permit is required.
- All wood must be pressure treated or naturally resistant to decay. Treat cuts, holes and notches with end-cut solution.
- Fasteners, hangers, nails, etc., must be stainless steel, hot-dipped galvanized, or as specifically required for the specified wood preservative used. The coating weights for zinc-coated fasteners to be in accordance with ASTM A 153. Provide documentation in the field showing the required fastener protection for the wood chosen for your deck.
- You may modify any components of this Tip Sheet using accepted engineering practices. Any modifications must be reviewed prior to permit issuance. All attachments must be per manufacturer’s installation instructions.
- This Tip Sheet is intended to represent good construction practices for deck construction and related IRC requirements. See related Tip Sheets: 1 for stairs, 2 for handrails, and 3 for guards.

Typical Deck Section

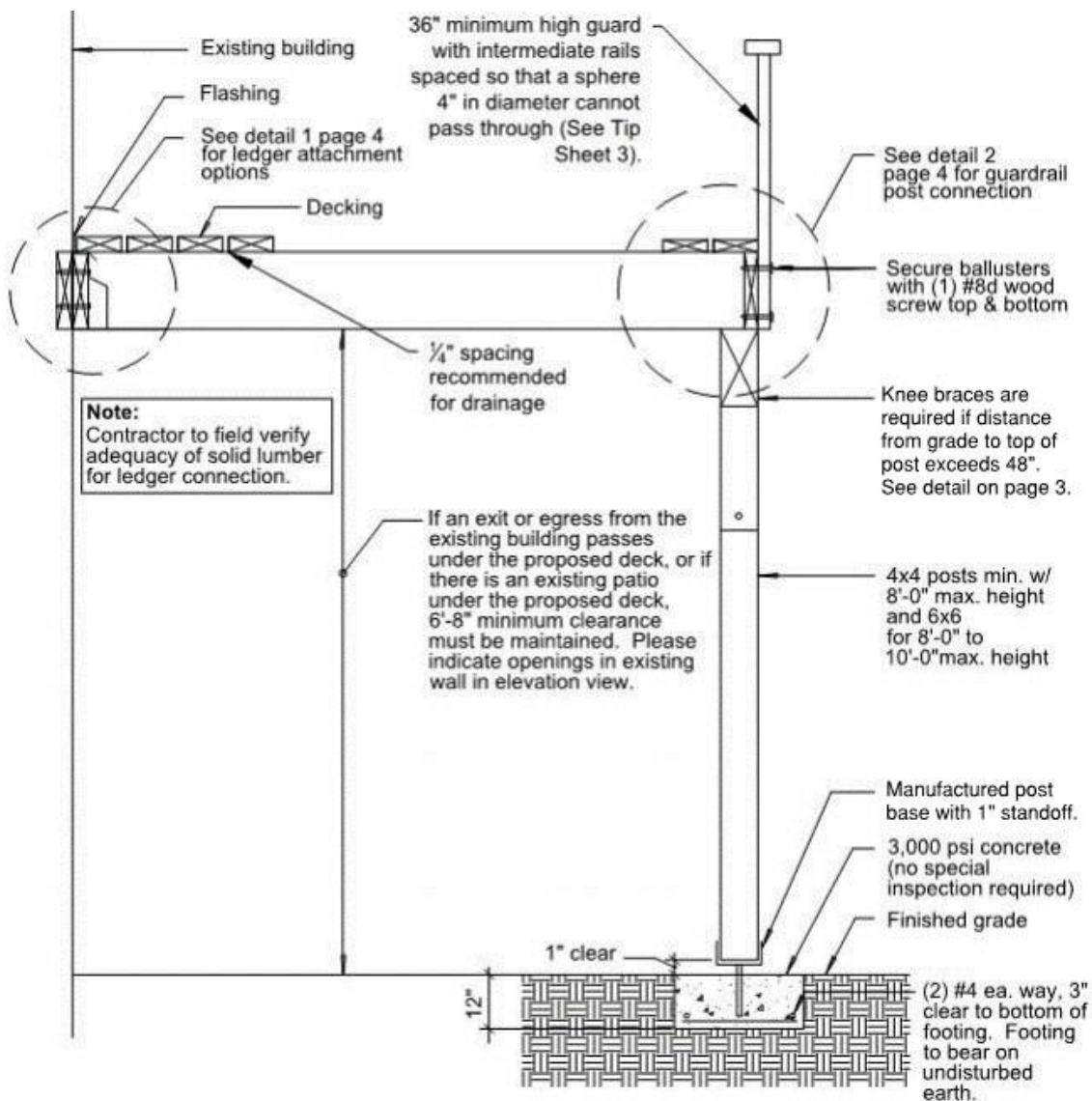

GENERAL INFORMATION:

- The intent of this Tip Sheet is to provide a general understanding of the code requirements and does not address the subject in great detail.
- Additional information can be obtained from your local participating jurisdiction.

Post to Beam Connection w/ Knee Brace

(Knee braces are required on posts greater than 4 feet in height.)

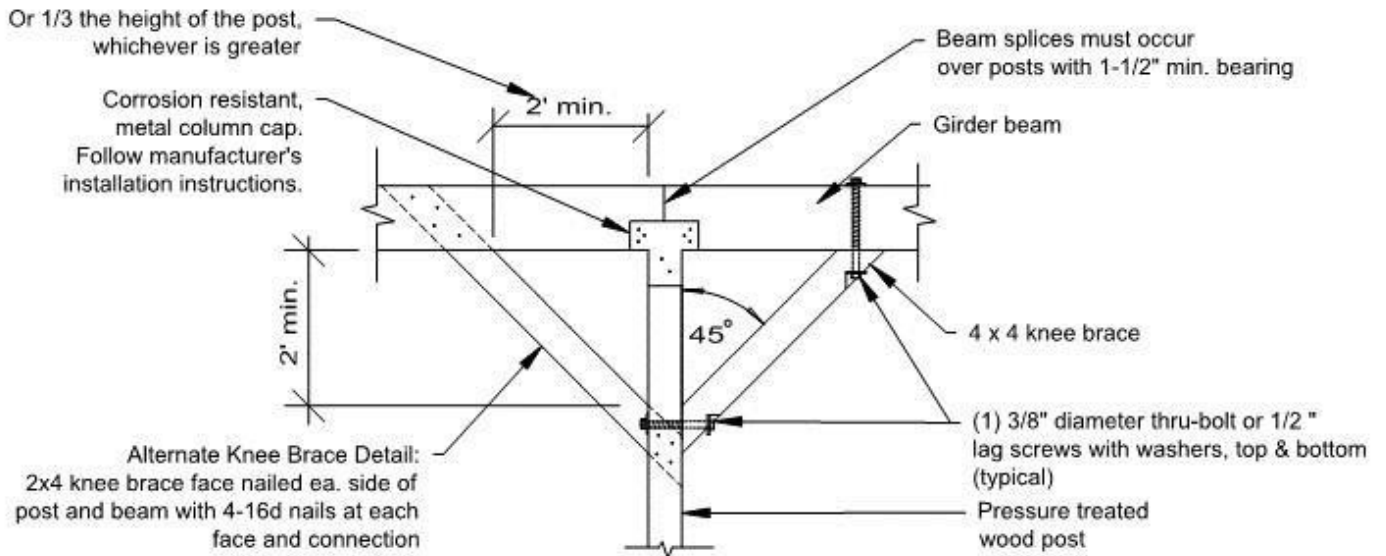

Guardrail Attachment

(Guardrails are required when the deck is more than 30 inches above grade.)

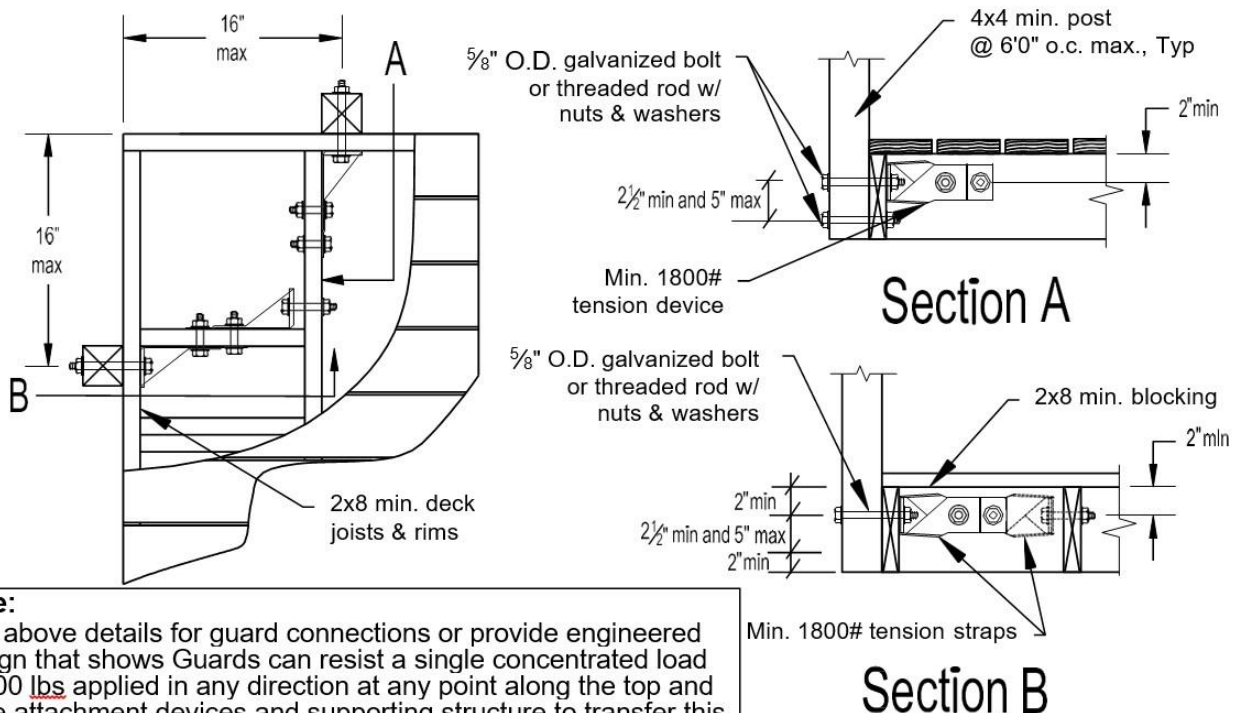

Note:
Use above details for guard connections or provide engineered design that shows Guards can resist a single concentrated load of 200 lbs applied in any direction at any point along the top and have attachment devices and supporting structure to transfer this load to appropriate structural elements of the building per IBC sec 1607.7.1.1

GENERAL INFORMATION:

- The intent of this Tip Sheet is to provide a general understanding of the code requirements and does not address the subject in great detail.
- Additional information can be obtained from your local participating jurisdiction.

Detail 1 – Ledger Attachment for Lateral Loads

(Knee braces are required on posts greater than 4 feet in height.)

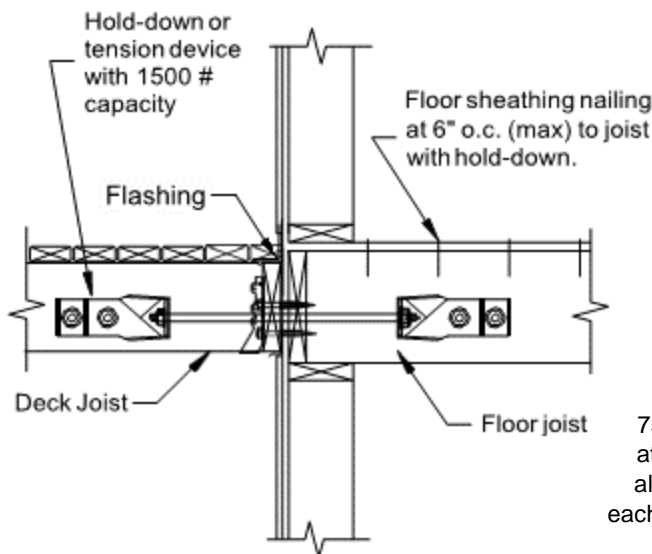

Option # 1
(Required for New Construction)

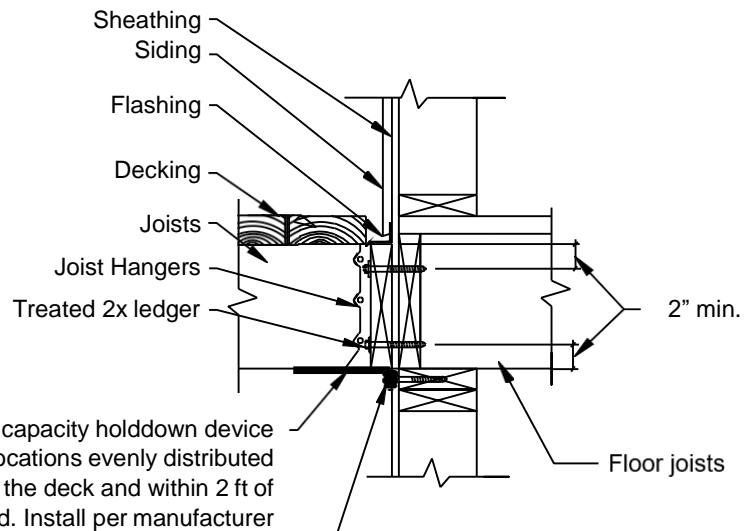

Option # 2
(Existing Construction Only)

Deck Connections

(All fasteners, nails, bolts, screws and connectors must be corrosion resistant.)

Connection:	Fastening:
Manufactured Connectors	Follow manufacturer's instructions
Post to Footing	Post base is required
Post to Footing (High Winds)	Consult with jurisdiction about additional uplift loads where wind exposure is greater than Risk Category B.
Post to Beam	Connector is required
Ledger to House Framing	See information on Sheet 5 and Sheet 6
Joist to Beam or Girder	(3) 8d – Toe nailed
Blocking or Bridging to Joist	(2) 10d –Toe nailed @ each end
Wooden Deck Boards	(2) 8d threaded nails <u>OR</u> (2) No. 8 screws
Composite Decking	Follow manufacturer's instructions

GENERAL INFORMATION:

- The intent of this Tip Sheet is to provide a general understanding of the code requirements and does not address the subject in great detail.
- Additional information can be obtained from your local participating jurisdiction.

Span Table and Footing Schedule for Decks

Spans and footings assume the maximum 24" cantilever using Hem-Fir/Doug Fir No. 2 or better framing lumber.
Table uses 70 psf. loading (10 psf. dead load + 60 psf live load) and 2000 psf. soil bearing pressure.

Joist Size	Joist Spacing	Max. Joist Span	Girder Beam Size and Max. Span Between Support Posts / Footing Type							
			4x6	Footing	4x8	Footing	4x10	Footing	4x12	Footing
2x6	12" o.c.	7'-5"	5'-11"	14x14	7'-9"	16x16	9'-6"	18x18	11'-1"	18x18
	16" o.c.	6'-9"	5'-11"	14x14	7'-9"	16x16	9'-6"	18x18	11'-1"	18x18
	24" o.c.	5'-9"	6'-3"	14x14	8'-9"	16x16	11'-0"	18x18	12'-10"	18x18
2x8	12" o.c.	9'-7"	4'-11"	14x14	6'-6"	16x16	8'-3"	18x18	10'-0"	20x20
	16" o.c.	8'-8"	4'-11"	14x14	6'-6"	16x16	8'-3"	18x18	10'-0"	18x18
	24" o.c.	7'-7"	5'-11"	14x14	7'-9"	16x16	9'-6"	18x18	11'-1"	18x18
2x10	12" o.c.	13'-3"	3'-6"	14x14	4'-8"	16x16	5'-11"	18x18	7'-2"	18x18
	16" o.c.	11'-6"	4'-1"	14x14	5'-5"	16x16	6'-11"	18x18	8'-5"	20x20
	24" o.c.	9'-5"	4'-11"	14x14	6'-6"	16x16	8'-3"	18x18	10'-0"	20x20
2x12	12" o.c.	15'-5"	3'-1"	14x14	4'-1"	16x16	5'-2"	16x16	6'-3"	18x18
	16" o.c.	13'-4"	3'-6"	14x14	4'-8"	16x16	5'-11"	18x18	7'-2"	18x18
	24" o.c.	10'-11"	4'-1"	14x14	5'-5"	16x16	6'-11"	18x18	8'-5"	18x18

Footings must have a minimum reinforcement of (2) #4 bars each way with a 3" clearance to the bottom of the footing.

Note: Footing sizes are based on decks designed with single span joists where there is no center bearing beam.

Deck Ledger Connection to Band Joist ^{a, b}

(Reference IRC Table R507.2 - Deck live load = 60 psf, deck dead load = 10 psf, snow load ≤ 40 psf)

For SI: 1 inch = 25.4 mm, 1 foot = 304.8 mm, 1 pound per square foot = 0.0479 kPa.

Connection Details	Joist Span						
	6' and less	6'1" to 8'	8'1" to 10'	10'1" to 12'	12'1" to 14'	14'1" to 16'	16'1" to 18'
	On-center spacing of fasteners						
½ inch diameter lag screw with ½ inch maximum sheathing ^{c,d}	22	16	13	11	9	8	7
½ inch diameter bolt with ½ inch maximum sheathing ^d	30	22	18	15	13	11	10
½ inch diameter bolt with 1 inch maximum sheathing ^e	26	19	16	13	11	10	9

- a. Ledgers shall be flashed in accordance with Section R703.4 to prevent water from contacting the house band joist.
- b. Snow load shall not be assumed to act concurrently with live load.
- c. The tip of the lag screw shall fully extend beyond the inside face of the band joist.
- d. Sheathing shall be wood structural panel or solid sawn lumber.
- e. Sheathing shall be permitted to be wood structural panel, gypsum board, fiberboard, lumber or foam sheathing. Up to 1/2-inch thickness of stacked washers shall be permitted to substitute for up to ½-inch of allowable sheathing thickness where combined with wood structural panel or lumber sheathing.

GENERAL INFORMATION:

- The intent of this Tip Sheet is to provide a general understanding of the code requirements and does not address the subject in great detail.
- Additional information can be obtained from your local participating jurisdiction.



Placement of Lag Screws and Bolts in Ledgers and Band Joists

(Reference IRC Table 507.2.1)

Minimum End and Edge Distance and Spacing Between Rows				
	Top Edge	Bottom Edge	Ends	Row Spacing
Ledger ^a	2 inches ^d	3/4 inch	2 inches ^b	1 5/8 inches ^b
Band joist ^c	3/4 inch	2 inches ^e	2 inches ^b	1 5/8 inches ^b

For SI: 1 inch = 25.4mm

- a. Lag screws or bolts must be staggered from the top and bottom along the horizontal run. See figure below.
- b. Maximum 5 inches.
- c. For engineered rim joists, the manufacturer's recommendations govern.
- d. The minimum distance from the bottom row to the top edge of the ledger must be in accordance with figure below.
- e. 2 inches may be reduced to 3/4 inch when the band joist is directly supported by a mudsill, header, or by double top wall plates.

Placement of Lag Screws and Bolts in Ledgers

(Reference IRC Figure 507.2.1(1))

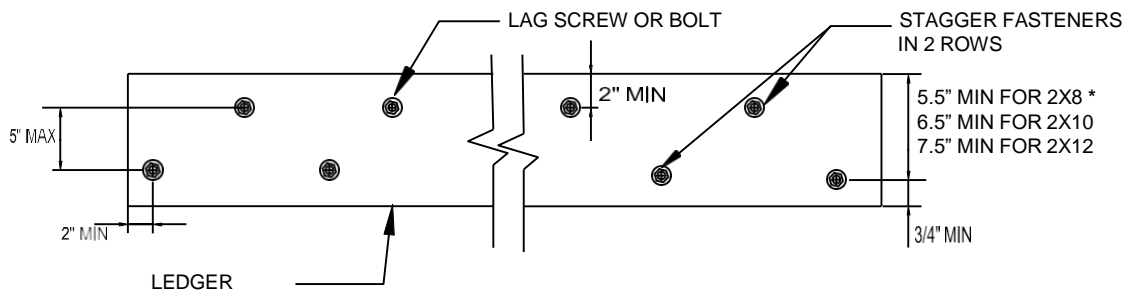

*DISTANCE CAN BE REDUCED TO 4.5" IF LAG SCREWS ARE USED OR IF BOLT SPACING IS REDUCED TO THAT OF LAG SCREWS TO ATTACH 2X8 LEDGERS TO 2X8 BAND JOISTS.

Placement of Lag Screws and Bolts in Ledgers

(Reference IRC Figure 507.2.1(2))

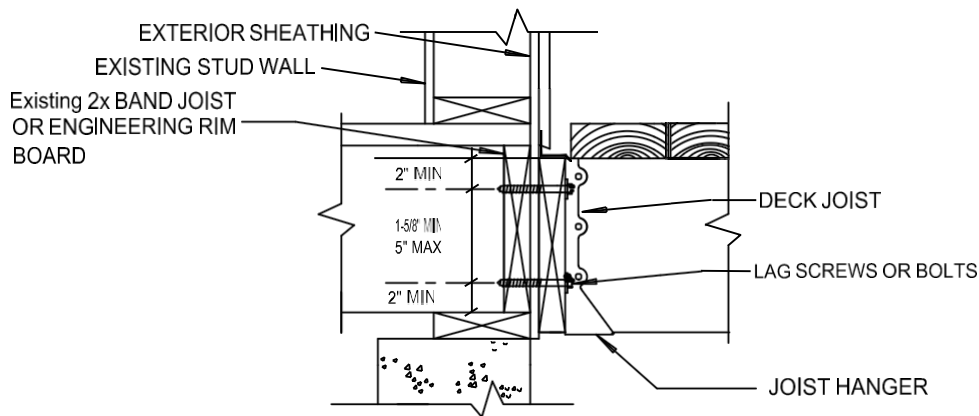

GENERAL INFORMATION:

- The intent of this Tip Sheet is to provide a general understanding of the code requirements and does not address the subject in great detail.
- Additional information can be obtained from your local participating jurisdiction.